Yale UX Series

Internal Combustion Counterbalanced Forklift

GP20-35UX / 2000 - 3500kg



Features

1 High Strength OHG ▶

The overhead guard features profiled steel with high strength glass to enhance reliability and operator protection.

2 Suspension Seat ▶

A full suspension seat that offers excellence in comfort, with an operator presence system fitted as standard.

3 Low Step Driver Height ▶

Convenient step placing to suit a variety of heights to ensure easy access to the truck at all times.





◀ **4** **Wide View Mast**

The wide mast features an outside width of 720mm. It can significantly improve the driver's front field of view while increasing the safety and comfort of operating the truck.

◀ **5** **Small Steering Wheel**

The adjustable steering wheel is convenient for the operator as it provides 8 degrees of adjustment. It is also easy to navigate when working in narrow spaces.

◀ **6** **Japanese Powertrain**

The UX powertrain is sourced from Japanese manufactured components which ensures reliability and ease of sourcing replacement parts.

GP20-35UX

The Yale® UX Series provides the ideal solution to meet your less frequent usage needs, without compromising on performance.

► The Range

The range consists of 2,000 - 3,500kg. IC counterbalance, pneumatic tyre forklift trucks, available in four different capacities:

2,000kg – GP20UX / 2,500kg – GP25UX
3,000kg – GP35UX / 3,500kg – GP35UX

Each model is available with diesel, LPG or dual-fuel power, a single-speed powershift transmission and a range of front end equipment options to suit varying application requirements.

► Easy to Operate

The ergonomically designed operator compartment, with a familiar automotive layout, means that drivers will be able to work comfortably. A range of standard features and options help to ensure that the truck is configured to the needs of the application.

► Serviceability

Due to the simplicity of the components and specifications, servicing can be carried out quickly and easily.

► Low Cost of Ownership

The use of high quality, robust components, efficient filtration and excellent cooling helps contribute to reliable operations and lower wear and tear. This, together with the fast availability of cost-effective replacement parts helps to reduce service and maintenance requirements and costs.

► Comfort

- Yale special display with 3.5" LCD
- Large foot room on floor plate
- Dual suspension system
- Hand parking brake lever with button greatly reduces fatigue in operation
- Small diameter steering wheel with adjustable steering column

► Safety and Stability

- Wide view mast
- High strength overhead guard
- Muffler and engine protective system
- Lower centre of gravity

► Easy Maintenance

- Large access area for service and repairs
- Simple components
- Computer-based diagnostics not required

► Reliability and Exchangeability

- Triplex plate overhead guard
- Exchangeable components across models

► Environmental Protection

- Noise isolation material
- Environmentally-aware design

Engineered for drivers with Comfort, Safety and Ergonomics



▶ Yale Display with 3.5" LCD

- The Yale UX Series Forklift adopts a 3.5" LCD display, providing convenient viewing of the display data when driving and operating



▶ Hand Parking Brake

- Low effort to operate park brake lever
- Hand parking brake lever with button reduces operator fatigue



▶ Large Foot Room

- Spacious foot room design provides comfort, convenience and safety
- Control pedals provide extra foot space which reduces operator fatigue and increases operator comfort

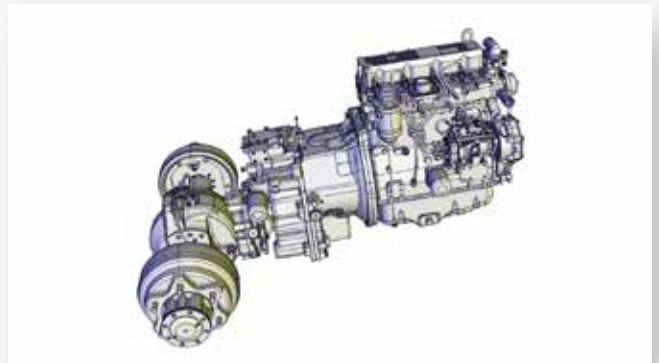

▶ Dual Suspension System

- The specialised dual-suspension system decreases vibration and noise
- Full floating safeguard/cabin system
- Engine vibration damper
- Suspended transmission replaces traditional rigid connections



▶ **Small Diameter Steering Wheel with Adjustable Steer Column**

- The 300mm diameter steering wheel is easy to manipulate, responsive, and ensures optimum mobility when working in a narrow space
- The ideally positioned steering wheel allows 8 degrees of adjustment, to suit a variety of different operators



▶ **High Strength Overhead Guard**

- Profiled steel overhead guard
- High strength roof with high strength glass enhances reliability and operator protection
- Mast composite roller structure



▶ **Wide View Mast**

- The wide view mast with an outside width of 720mm, significantly improves the driver's front field of view, reduces blind spots, and increases the safety and comfort of the operation



▶ **Large Access Area for Service and Repairs**

- Large access space to engine compartment makes service and repairs more convenient



▶ Suspension Seat

- Full suspension seat offers excellent comfort
- Operator presence system as standard



▶ Triplex Plate Overhead Guard

- The overhead guard is developed using three pieces; left side, right side and top canopy making replacement more convenient



▶ Exchangeable Components

- Engine cover, instrument panel, display and most other components are exchangeable with other capacities in the same range
- Front fenders adaptable to single or dual wheel configuration

▶ Improved Lifting Speed

- Competitive lifting speeds

Options

Yale UX Series trucks feature a comprehensive range of standard equipment, with a number of options available to suit the specific needs of your application, including:

- LPG, dual-fuel or diesel
- Pneumatic-shaped solid, or dual tyres
- Various fork lengths
- Integral sideshift
- Swing-out drop down LPG bracket
- Rear, LED work light
- Strobe light
- Backup alarm
- High air intake with pre-cleaner
- Tilt cylinder boots
- Various mast heights
- 3 way catalytic purifier on LPG engines
- Glass roof
- Front window with wiper

Please refer to the Price List for full option configurations.

Truck Dimensions

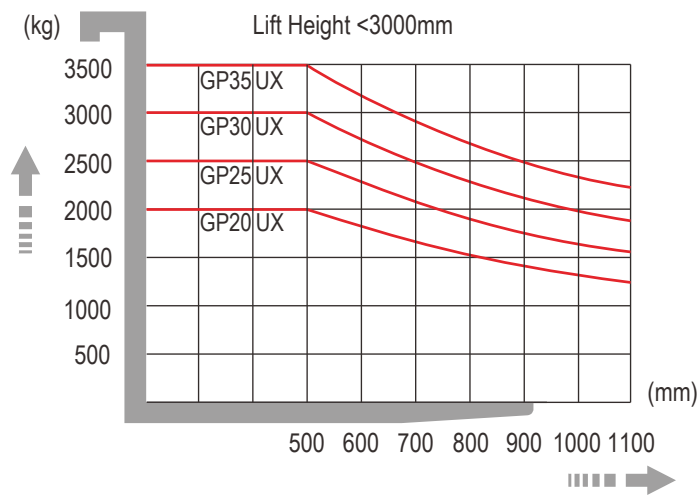
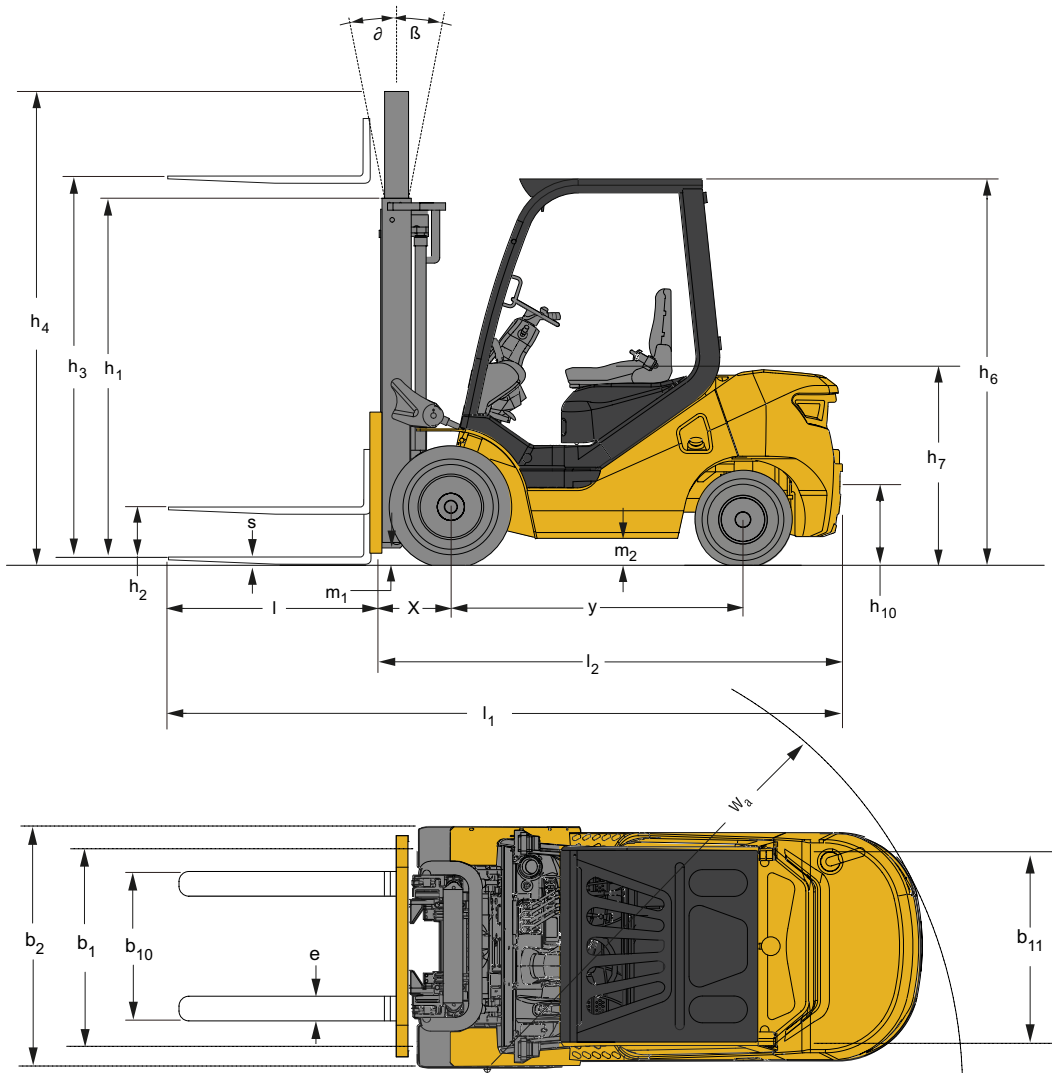

▶ GP20UX Rated Capacity KG@ 500MM Load Centre

	Maximum fork height $h_3 + s$ (mm)	Mast tilt		Lowered height h_1 (mm)	Extended height h_4 (mm) (1)	Extended height h_4 (mm) (2)	Free lift height $h_2 + s$ (m) (1)	Without Sideshift	
		FWD tilt (°)	Back tilt (°)					GP20UX	
								Single Tyre	Dual Tyre
2-STAGE LIMITED FREE LIFT	3000	6	12	2010	3575	3990	160	2000	2000
	3300	6	12	2160	3875	4290	160	2000	2000
	3700	6	6	2360	4275	4690	160	2000	2000
3-STAGE FULL FREE LIFT	4500	6	6	2060	5017	5490	1440	1600	1800
	4800	6	6	2160	5317	5790	1540	1250	1700
	5500	3	6	2425	6017	6490	1800	900	1400

Note: For integral sideshifts deduct 50kg from stated capacity

▶ GP25UX Rated Capacity KG@ 500MM Load Centre

	Maximum fork height $h_3 + s$ (mm)	Mast tilt		Lowered height h_1 (mm)	Extended height h_4 (mm) (1)	Extended height h_4 (mm) (2)	Free lift height $h_2 + s$ (m) (1)	Without Sideshift	
		FWD tilt (°)	Back tilt (°)					GP25UX	
								Single Tyre	Dual Tyre
2-STAGE LIMITED FREE LIFT	3000	6	12	2010	3575	3990	160	2500	2500
	3300	6	12	2160	3875	4290	160	2500	2500
	3700	6	6	2360	4275	4690	160	2500	2500
3-STAGE FULL FREE LIFT	4500	6	6	2060	5017	5490	1440	2000	2300
	4800	6	6	2160	5317	5790	1540	1700	2000
	5500	3	6	2425	6017	6490	1800	1200	1600

Note: For integral sideshifts deduct 50kg from stated capacity

▶ GP30UX Rated Capacity KG@ 500MM Load Centre

	Maximum fork height $h_3 + s$ (mm)	Mast tilt		Lowered height h_1 (mm)	Extended height h_4 (mm) (1)	Extended height h_4 (mm) (2)	Free lift height $h_2 + s$ (m) (1)	Without Sideshift	
		FWD tilt (°)	Back tilt (°)					GP30UX	
								Single Tyre	Dual Tyre
2-STAGE LIMITED FREE LIFT	3000	6	12	2075	3640	4100	165	3000	3000
	3300	6	12	2225	3940	4400	165	3000	3000
	3700	6	6	2425	4340	4800	165	3000	3000
3-STAGE FULL FREE LIFT	4500	6	6	2125	5100	5600	1525	2500	2700
	4800	6	6	2225	5400	5900	1625	2250	2450
	5500	3	6	2490	6100	6600	1880	1650	2100

Note: For integral sideshifts deduct 50kg from stated capacity

▶ GP35UX Rated Capacity KG@ 500MM Load Centre

	Maximum fork height $h_3 + s$ (mm)	Mast tilt		Lowered height h_1 (mm)	Extended height h_4 (mm) (1)	Extended height h_4 (mm) (2)	Free lift height $h_2 + s$ (m) (1)	Without Sideshift	
		FWD tilt (°)	Back tilt (°)					GP35UX	
								Single Tyre	Dual Tyre
2-STAGE LIMITED FREE LIFT	3000	6	12	2150	3700	4100	165	3500	3500
	3300	6	12	2300	4000	4400	165	3500	3500
	3700	6	6	2500	4400	4800	165	3500	3500
3-STAGE FULL FREE LIFT	4500	6	6	2200	5140	5600	1525	2800	3000
	4800	6	6	2300	5440	5900	1625	2500	2750
	5500	3	6	2565	6140	6600	1880	1800	2300

Note: For integral sideshifts deduct 50kg from stated capacity

GDP20 - 35UX Diesel Forklift Specifications

			YALE	YALE	YALE	YALE	YALE	YALE
Distinguishing Marks	1.1	Manufacturer						
	1.2	Manufacturer's type designation	GDP20UX	GDP25UX	GDP30UX	GDP30UX	GDP35UX	GDP35UX
		Engine / transmission	Yanmar 2.6L	Yanmar 2.6L	Yanmar 3.0L	Yanmar 3.3L	Yanmar 3.0L	Yanmar 3.3L
	1.3	Drive: electric (battery or mains), diesel, petrol, fuel gas	DIESEL	DIESEL	DIESEL	DIESEL	DIESEL	DIESEL
	1.4	Operator type: hand, pedestrian, standing, seated, order-picker	Seated	Seated	Seated	Seated	Seated	Seated
	1.5	Rated capacity/rated load	Q (kg)	2000	2500	3000	3000	3500
	1.6	Load centre distance	c (mm)	500	500	500	500	500
	1.8	Load distance, centre of drive axle to fork	x (mm)	475	475	490	490	510
	1.9	Wheelbase	y (mm)	1600	1600	1700	1700	1700
Weights	2.1	Service weight	kg	3390	3650	4300	4300	4710
	2.2	Axle loading, laden front / rear	kg	4760 / 630	5320 / 650	6490 / 770	6490 / 810	7250 / 960
	2.3	Axle loading, unladen front / rear	kg	1540 / 1850	1500 / 2150	1710 / 2590	1710 / 2590	1690 / 3020
Tyres/Chassis	3.1	Tyre type		Pneumatic	Pneumatic	Pneumatic	Pneumatic	Pneumatic
	3.2	Tyre size, front		7.00-12NHS-12	7.00-12NHS-12	28x9-15NHS-14PR	28x9-15NHS-14PR	28x9-15NHS-14PR
	3.3	Tyre size, rear		6.00-9NHS-10	6.00-9NHS-10	6.500-10NHS-10PR	6.500-10NHS-12PR	6.500-10NHS-10PR
	3.5	Wheels, number front/rear (X = driven wheels)		2X/2	2X/2	2X/2	2X/2	2X/2
	3.6	Tread, front	b10 (mm)	970	970	1000	1000	1000
	3.7	Tread, rear	b11 (mm)	980	980	970	970	970
Dimensions	4.1	Tilt of mast / fork carriage forward / backward	(°)	6 / 12	6 / 12	6 / 12	6 / 12	6 / 12
	4.2	Height, mast lowered	h10 (mm)	2010	2010	2075	2075	2150
	4.3	Free lift	h2 (mm)	160	160	165	165	165
	4.4	Lift	h3 (mm)	3000	3000	3000	3000	3000
	4.5	Height of mast, extended wo / LBR	h4 (mm)	3575	3575	3640	3640	3700
	4.5	Height of mast, extended w / LBR	h4 (mm)	4025	4025	4140	4140	4140
	4.7	Height of overhead guard	h6 (mm)	2180	2180	2205	2205	2205
	4.8	Seat height / stand height	h7 (mm)	1167	1167	1192	1192	1192
	4.12	Coupling height	h10 (mm)	250	250	480	480	480
	4.19	Overall length	l1 (mm)	3630	3690	3804	3804	3894
	4.20	Length to face of forks	l2 (mm)	2560	2620	2734	2734	2824
	4.21	Overall width (Standard / Dual)	b1/b2 (mm)	1150 / 1590	1150 / 1590	1210 / 1650	1210 / 1650	1210 / 1650
	4.22	Fork dimensions	s/e/l (mm)	40 x 122 x 1070	40 x 122 x 1070	45 x 122 x 1070	45 x 122 x 1070	45 x 122 x 1070
	4.23	Fork carriage to DIN 15173. Class, A/B		A	A	A	A	A
	4.24	Fork carriage width	b3 (mm)	1040	1040	1100	1100	1100
	4.31	Ground clearance, laden, below mast	m1 (mm)	125	125	130	130	130
	4.32	Ground clearance, centre of wheelbase	m2 (mm)	150	150	145	145	145
	4.34.1	Aisle width with pallets 1000 long x 1200 wide	Ast (mm)	3966	4026	4126	4126	4210
	4.34.2	Aisle width with pallets 800 wide x 1200 long	Ast (mm)	3766	3826	3926	3926	4010
	4.35	Turning radius	Wa (mm)	2290	2350	2430	2430	2500
	4.36	Internal turning radius	b13 (mm)	136	136	203	203	203
	4.42	Step height (from ground to running board)	k (mm)	430	430	455	455	455
	Performance Data	5.1	Travel speed, laden / unladen	km/h	20 / 20	20 / 20	20 / 20	18 / 19
5.2		Lift speed, laden / unladen	m/s	0.54 / 0.57	0.54 / 0.57	0.46 / 0.49	0.42 / 0.45	0.33 / 0.36
5.3		Lowering speed, laden / unladen	m/s	0.43 / 0.40	0.43 / 0.40	0.38 / 0.36	0.4 / 0.38	0.4 / 0.38
5.5		Drawbar pull, laden / unladen @ 1.6 km/h	N	10219/8589	10118/8259	12875/9498	13553/9498	13516/9676
5.5		Drawbar pull, laden / unladen @ 4.8 km/h	N	4879/7544	4879/7185	8498/8119	7319/8119	8879/8892
5.6		Max. drawbar pull, laden / unladen	N	12774/8761	12648/8450	16094/9688	16941/9688	16870/9676
5.7		Gradeability, laden / unladen @ 4.8 km/h	%	18.7/25.6	16.3/22.3	21.2/22.3	21.2/22.3	16.7/20.7
5.8		Max. gradeability, laden / unladen @ 1.6 km/h	%	10.4/22.4	8.8/19.5	14/18	12.5/19	10.9/19
5.10		Service brake		Hydraulic	Hydraulic	Hydraulic	Hydraulic	Hydraulic
Combustion Engine		7.1	Engine manufacturer/type		Yanmar 2.6L	Yanmar 2.6L	Yanmar 3.0L	Yanmar 3.3L
	7.2	Engine power according to ISO 1585	kW	33	33	35.5	42.1	35.5
	7.3	Rated speed	min-1	2450	2450	2400	2300	2400
	7.4	Number of cylinders/displacements	(-)/cm3	4 / 2659	4 / 2659	4 / 3054	4 / 3319	4 / 3054
	7.5	Fuel consumption according to VDI cycle	l/h or kg/h	🔪	🔪	🔪	🔪	🔪
Additional Data	8.1	Type of drive unit		Automatic	Automatic	Automatic	Automatic	Automatic
	10.1	Operating pressure for attachments	bar	0-175	0-175	0-175	0-175	0-175
	10.2	Oil volume for attachments	l/min	64	64	64	64	64
	10.7	Average noise level at operator's ear (no cab)	dB(A)	84	84	84	84	84
	10.7.1	Guaranteed sound power 2001/14/EC	dB(A)	104	104	104	104	104
10.8	Towing coupling, type DIN		PIN	PIN	PIN	PIN	PIN	

		1.1	YALE	YALE	YALE	YALE	YALE	YALE	
Distinguishing Marks	1.2	Manufacturer's type designation	GLP20UX	GLP20UX	GLP25UX	GLP25UX	GLP30UX	GLP35UX	
		Engine / transmission	GCT K21	GCT K25	GCT K21	GCT K25	GCT K25	GCT K25	
	1.3	Drive: electric (battery or mains), diesel, petrol, fuel gas	LPG / PETROL	LPG / PETROL	LPG / PETROL	LPG / PETROL	LPG / PETROL	LPG / PETROL	
	1.4	Operator type: hand, pedestrian, standing, seated, order-picker	Seated	Seated	Seated	Seated	Seated	Seated	
	1.5	Rated capacity/rated load	Q (kg)	2000	2000	2500	2500	3000	3500
	1.6	Load centre distance	c (mm)	500	500	500	500	500	500
	1.8	Load distance, centre of drive axle to fork	x (mm)	475	475	475	475	490	510
	1.9	Wheelbase	y (mm)	1600	1600	1600	1600	1700	1700
	Weights	2.1	Service weight	kg	3390	3390	3650	3650	4300
2.2		Axle loading, laden front / rear	kg	4760 / 630	4760 / 630	5400 / 650	5400 / 650	6490 / 810	7250 / 960
2.3		Axle loading, unladen front / rear	kg	1540 / 1850	1540 / 1850	1500 / 2150	1500 / 2150	1710 / 2590	1690 / 3020
Tyres/Chassis	3.1	Tyre type		Pneumatic	Pneumatic	Pneumatic	Pneumatic	Pneumatic	Pneumatic
	3.2	Tyre size, front		7.00-12NHS-12	7.00-12NHS-12	7.00-12NHS-12	7.00-12NHS-12	28x9-15NHS-14PR	28x9-15NHS-14PR
	3.3	Tyre size, rear		6.00-9NHS-10	6.00-9NHS-10	6.00-9NHS-10	6.00-9NHS-10	6.500-10NHS-14PR	6.500-10NHS-10PR
	3.5	Wheels, number front/rear (X = driven wheels)		2X/2	2X/2	2X/2	2X/2	2X/2	2X/2
	3.6	Tread, front	b10 (mm)	970	970	970	970	1000	1000
	3.7	Tread, rear	b11 (mm)	980	980	980	980	970	970
	Dimensions	4.1	Tilt of mast / fork carriage forward / backward	(°)	6 / 12	6 / 12	6 / 12	6 / 12	6 / 12
4.2		Height, mast lowered	h10 (mm)	2010	2010	2010	2010	2075	2150
4.3		Free lift	h2 (mm)	160	160	160	160	165	165
4.4		Lift	h3 (mm)	3000	3000	3000	3000	3000	3000
4.5		Height of mast, extended wo / LBR	h4 (mm)	3575	3575	3575	3575	3640	3700
4.5		Height of mast, extended w / LBR	h4 (mm)	4025	4025	4025	4025	4140	4140
4.7		Height of overhead guard	h6 (mm)	2180	2180	2180	2180	2205	2205
4.8		Seat height / stand height	h7 (mm)	1167	1167	1167	1167	1192	1192
4.12		Coupling height	h10 (mm)	250	250	250	250	480	480
4.19		Overall length	l1 (mm)	3630	3630	3690	3690	3804	3894
4.20		Length to face of forks	l2 (mm)	2560	2560	2620	2620	2734	2824
4.21		Overall width (Standard / Dual)	b1/b2 (mm)	1150 / 1590	1150 / 1590	1150 / 1590	1150 / 1590	1210 / 1650	1210 / 1650
4.22		Fork dimensions	s/e/l (mm)	40 x 122 x 1070	40 x 122 x 1070	40 x 122 x 1070	40 x 122 x 1070	45 x 122 x 1070	45 x 122 x 1070
4.23		Fork carriage to DIN 15173. Class, A/B		A	A	A	A	A	A
4.24		Fork carriage width	b3 (mm)	1040	1040	1040	1040	1100	1100
4.31		Ground clearance, laden, below mast	m1 (mm)	125	125	125	125	130	130
4.32		Ground clearance, centre of wheelbase	m2 (mm)	150	150	150	150	145	145
4.34.1		Aisle width with pallets 1000 long x 1200 wide	Ast (mm)	3966	3966	4026	4026	4126	4210
4.34.2		Aisle width with pallets 800 wide x 1200 long	Ast (mm)	3766	3766	3826	3826	3926	4010
4.35		Turning radius	Wa (mm)	2290	2290	2350	2350	2430	2500
4.36		Internal turning radius	b13 (mm)	136	136	136	136	203	203
4.42		Step height (from ground to running board)	k (mm)	430	430	430	430	455	455
Performance Data		5.1	Travel speed, laden / unladen	km/h	18 / 18	19 / 19	18 / 18	17.5 / 18	18 / 19
	5.2	Lift speed, laden / unladen	m/s	0.49 / 0.52	0.50 / 0.53	0.49 / 0.52	0.50 / 0.53	0.40 / 0.43	0.33 / 0.36
	5.3	Lowering speed, laden / unladen	m/s	0.43 / 0.40	0.42 / 0.39	0.43 / 0.40	0.42 / 0.39	0.40 / 0.38	0.40 / 0.38
	5.5	Drawbar pull, laden / unladen @ 1.6 km/h	N	12880/12880	12711/8589	12800/12800	12585/8259	14720/14720	12732/9676
	5.5	Drawbar pull, laden / unladen @ 4.8 km/h	N	9660/9600	6872/7544	9975/9975	6872/7185	11500/11500	6906/8892
	5.6	Max. drawbar pull, laden / unladen	N	15575/15575	16651/8761	15575/15575	16790/8450	17480/17480	16679/9870
	5.7	Gradeability, laden / unladen @ 4.8 km/h	%	23/23	23.7/25.6	20/20	20.4/22.3	19/19	18.7/22.3
	5.8	Max. gradeability, laden / unladen @ 1.6 km/h	%	17/23	13.1/22.4	14/20	11/19.5	13/19	10/19.5
	5.10	Service brake		Hydraulic	Hydraulic	Hydraulic	Hydraulic	Hydraulic	Hydraulic
	Combustion Engine	7.1	Engine manufacturer/type		GCT K21 LPG	GCT K25	GCT K21 LPG	GCT K25	GCT K25
7.2		Engine power according to ISO 1585	kW	31.2	37.4	31.2	37.4	37.4	37.4
7.3		Rated speed	min-1	2250	2300	2250	2300	2300	2300
7.4		Number of cylinders/displacements	(-)/cm3	4 / 2065	4 / 2488	4 / 2065	4 / 2488	4 / 2488	4 / 2488
7.5		Fuel consumption according to VDI cycle	l/h or kg/h	🔪	🔪	🔪	🔪	🔪	🔪
Additional Data	8.1	Type of drive unit		Automatic	Automatic	Automatic	Automatic	Automatic	Automatic
	10.1	Operating pressure for attachments	bar	0-175	0-175	0-175	0-175	0-175	0-175
	10.2	Oil volume for attachments	l/min	64	64	64	64	64	64
	10.7	Average noise level at operator's ear (no cab)	dB(A)	84	84	84	84	84	84
	10.7.1	Guaranteed sound power 2001/14/EC	dB(A)	103	103	103	103	103	103
10.8	Towing coupling, type DIN		PIN	PIN	PIN	PIN	PIN	PIN	